



Classic TBI 360 (DR)

Air cooled

DR: changeable swivel neck

TBi-Flex rubber coaxial cable

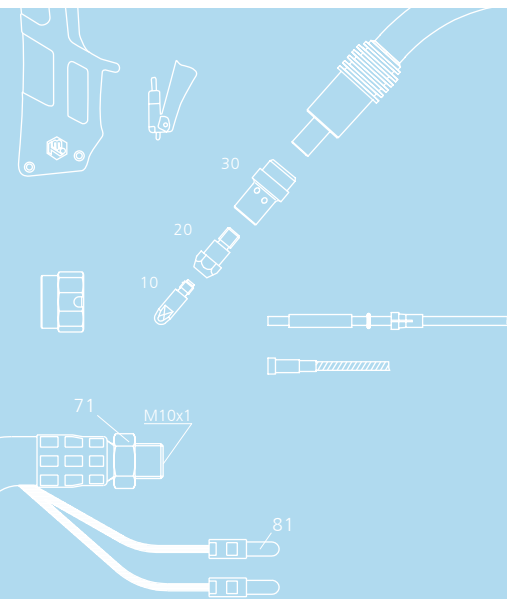

Technical data

MIG/MAG (GMAW) Semi-automatic welding torch TBI 360/360 DR

Rating at 60% duty cycle
(10 min. cycle)

- Mixed gas: 335 A
- CO₂: 350 A

Cooling method Air cooling

Wire diameter 1.0 - 1.2 mm

Gas flow 12 l/min

Technical specification according to IEC 60974-7

Weight with 1.5m cable 1.80 kg (TBI 360 DR: 2.10 kg)

Connection Euro-Central connector
Other connectors (e.g. CLOOS®,
ESAB®, Lincoln®) available upon
request.

Ordering information

TBi 360	ESG, 50° bent	114P3413_0*
TBi 360 DR	ESG, 45° bent	114P3413_D*

* At the blank, please insert 3, 4 or 5 for a torch length of 3, 4 or 5 m.

Torch rating will be reduced when using pulsed-arc power sources.
Special torch necks and custom lengths of the coaxial cable are
available upon request.

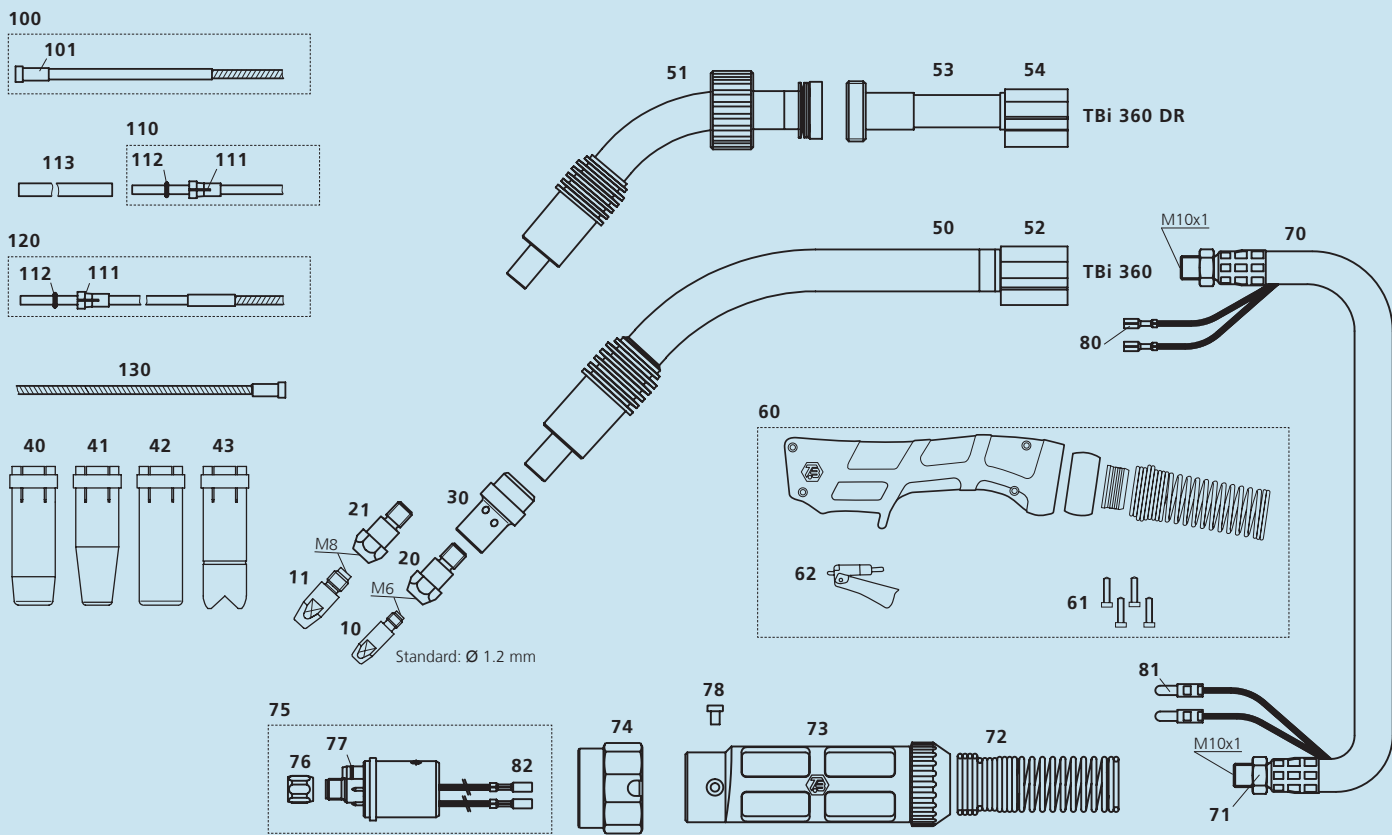

Pos. Description

Part no.

Contact tips

▶ 10	Contact tip M6x28, Ecu	340P_1069*
10	Contact tip M6x28, CuCrZr	340P_3069*
10	Contact tip M6x28 Alu, Ecu	341P_1069*
11	Contact tip M8x30, Ecu	340P_1262*
11	Contact tip M8x30, CuCrZr	340P_3262*
11	Contact tip M8x30 Alu, Ecu	341P_1262*

Tip holders

▶ 20	Tip holder M6 / L=28 mm	342P006014
20	Tip holder M6 / L=32 mm	342P006114
21	Tip holder M8 / L=28 mm	342P008014
21	Tip holder M8 / L=34 mm	342P008114

Gas diffusors

▶ 30	Gas diffusor, black	114P002007
30	Gas diffusor, white	114P002003
30	Gas diffusor, ceramic	114P002005
30	Gas diffusor, brown	114P002011

Gas nozzles

▶ 40	Nozzle con. diam. 16.0 mm	345P012010
41	Nozzle con. diam. 12.0 mm	345P013010
42	Nozzle cyl. diam. 20.0 mm	345P011010
43	Spot weld nozzle diam. 20.0 mm	345P015010

Spare parts

50	Torch neck TBi 360, 50°	114P001001
51	Torch neck TBi 360 DR (swivel), 45°	114P001015
52	PVC body	600P002018

Pos. Description

Part no.

53	Support for DR necks	600P101045
54	PVC body	600P002017
60	Handle blue, aircooled, cpl. kit	380P220400
61	Cross recessed screw M 3.5x14	100P008413
62	Trigger, red, 2 poles	385P021016
70	TBi-Flex coaxial cable 50 sqmm	360P5011_0*
71	Hex nut M10x1	101P002005
72	Spring support small 16-50 sqmm	600P102099
73	Cable support cpl. (2 pieces)	701P001045
74	Adaptor nut	701P001013
75	Central adaptor ESG cpl., 2 poles, moveable pins	701P001048
76	Sleeve nut M10x1	701P002005
77	O-ring 4.0x1.0 mm (gas nipple)	365P100040
78	Slotted screw M4x6	100P008401
80	Cable lug, flat	375P000023
81	Insulated connector, male, round	375P000004
82	Insulated connector, female, round	375P000003

Wire guides

▶ 100	Liner w/ insulation red (x.40 m) for wire 1.0-1.2	324P2045_4*
100	Liner w/ insulation yellow (x.40 m) for wire 1.2-1.6	324P2545_4*
101	Collet for liners dia. 4.5 mm	330P025045
110	Teflon liner red (x.50 m) for wire 1.0-1.2	326P2040_5*
110	Teflon liner yellow (x.50 m) for wire 1.2-1.6	326P2747_5*
111	Collet for teflon and PA liner 2.0x4.0 mm	331P020040
111	Collet for teflon and PA liner 2.7x4.7 mm	331P027047
112	O-ring 3.50x1.50 mm (teflon liner)	365P150035
113	Support tube 5x4.4 mm, L=150 mm	329P544150
120	PA-Alu wire guide (x.50 m) for wire 1.0-1.2	328P2040_A*
130	Liner for TBi DR Torch necks	322P204005

▶ = Standard parts

* At the blank, please insert suitable information for torch length or wire diameter, e.g. 08 for 0.8 mm or 3 for 3 m.

© 2008 TBI Industries GmbH. All rights reserved. Subject to change without notice. Warranty only when using original TBI consumables and spare parts. Excerpts and reprints not permitted.
Nr. DOKP111162, 11/2008.

TBI Industries GmbH
Ruhberg 14
D-35463 Fernwald-Steinbach
P.O. Box 67
D-35461 Fernwald-Steinbach

Tel. + 49 6404 9171-0
Fax. + 49 6404 9171-40
Internet: www.tbi-industries.com
E-mail: info@tbi-industries.com