



## TBi TD 20 / TD 22 MIG/MAG Tandem Welding Torch

Efficient 3-circuit water cooling system

Attractively priced consumables

High TCP precision



TBi TD 22 after welding

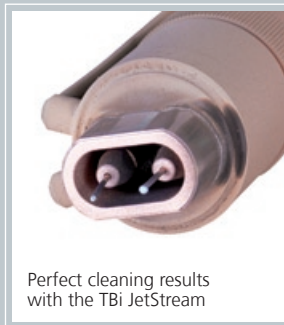

Perfect cleaning results  
with the TBi JetStream

### Technical data

#### Tandem welding torch TBi TD 20 / TD 22

Rating at 100% duty cycle  
(10 min. cycle)

- Mixed gas: 2 x 550 A

Cooling method 3-circuit water cooling

Wire diameter 1.0 – 3.2 mm

Distance between wire  
electrodes 10 mm with a stick-out of 20 mm  
(standard). Other distances are  
possible on request.

Gas flow max. 30 l/min

Blow-out function max. 10 bar, protective gas channel  
separated by check valve

Weight (without cables) approx. 2.8 kg

Technical specification according to IEC 60974-7

Options  
- wire run-in button on the torch  
- Push-pull system

Torch rating will be reduced when using pulsed-arc power sources. For heavy-duty use of the torch, it is highly recommended to use 3 separate water coolers, or a refrigerator unit.

### Ordering Information

TBi TD 20 Euro, 0° 042P0805\_\_\*

TBi TD 22 Euro, 22° bent 042P2805\_\_\*

\* At the blank, please insert the required cable length in decimeters, e.g. 12 for 1.2 m length.

## Torch mounts

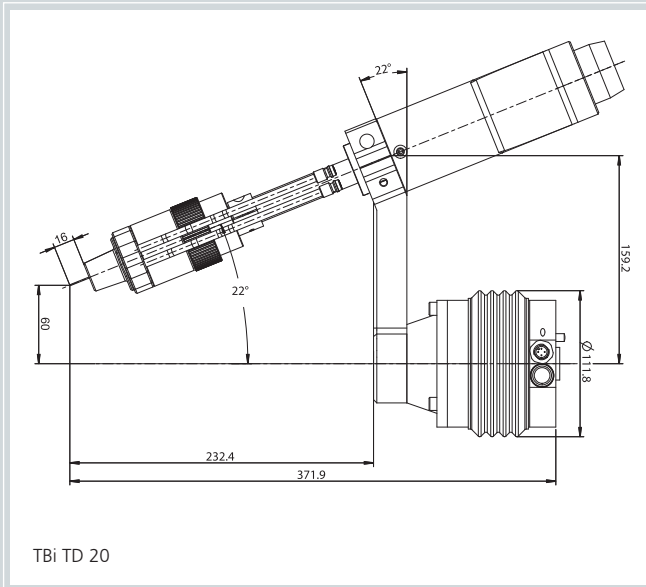

TBi TD 20

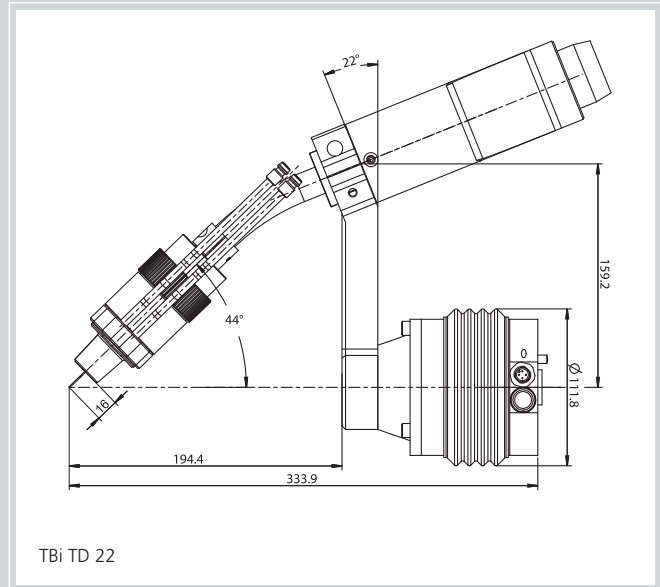

TBi TD 22

Torch mount 22° bent for TBi TD 20 and TBi TD 22, incl. screws

Part No.: 536P101700

## Consumables

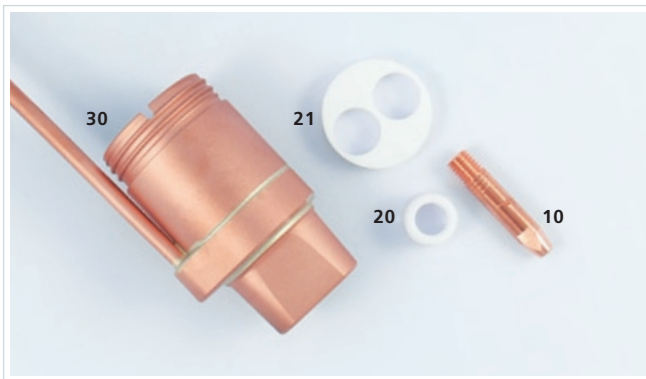

Pos. Description Part. No.

### Consumables and spare parts

10	Contact tip M10x50, CuCrZr	343P_3407*
20	Gas diffuser, ceramic	042P102081
21	Insulator, ceramic	346P014242
30	Gas nozzle, water cooled, oval	042P101025
-	Gas nozzle, water cooled, round	042P101023

### Wire guides

▶	Liner w/ insulation orange (x.40 m) for wire 1.6-2.0	324P2863_4*
-	Liner w/ insulation black (x.40 m) for wire 1.6-2.4	324P3570_4*
-	Liner w/ insulation grey (x.40 m) for wire 2.4-3.2	324P4570_4*

## Dimensions

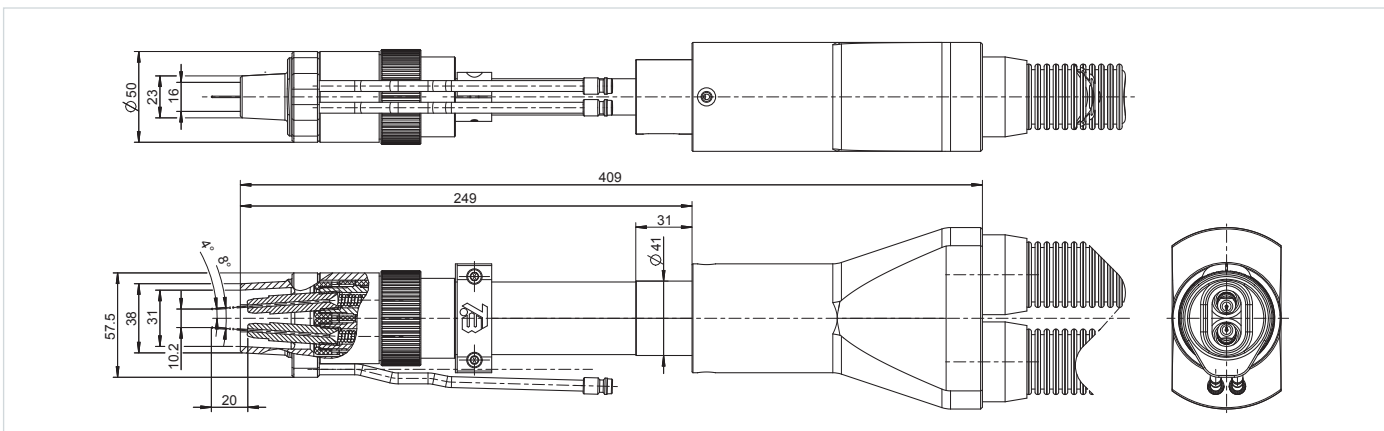

▶ = Standard equipment

\* At the blank, please insert suitable information for wire diameter or wire guide length, e.g. 08 for 0.8 mm or 3 for 3 m.

© 2011 TBi Industries GmbH. All rights reserved. Subject to change without notice. Warranty only when using original TBi consumables and spare parts. Excerpts and reprints not permitted. Nr. DOKP142012, 08/2011.