

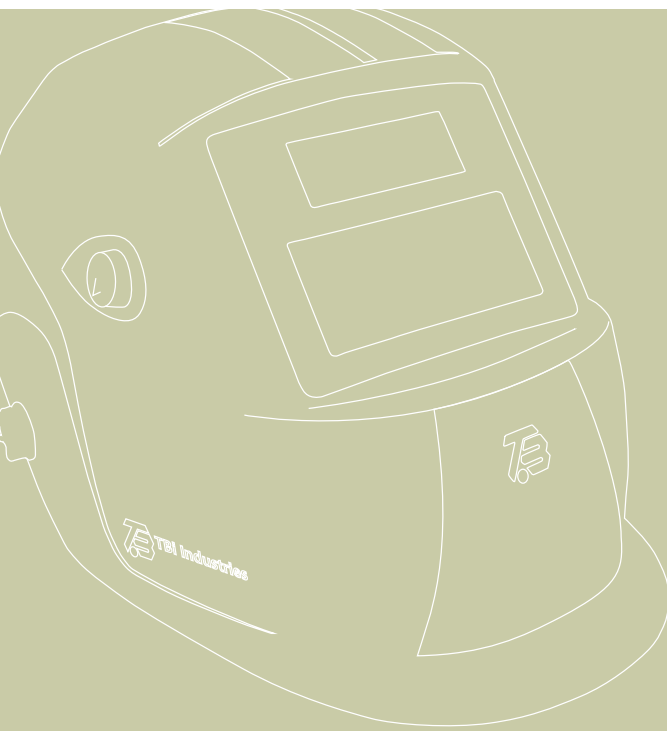

TBi ArcVisor Autodarkening Welding Helmet



- For MIG/MAG-, TIG-, Plasma welding and Plasma cutting
- Dark shade adjustable from DIN 9 – 13
- Very high optical grade filter

Technical data

TBi ArcVisor - autodarkening welding helmet

Viewing area	98 x 43 mm
Light state shade	DIN 4
Dark state shade	DIN 9–13, infinitely variable
UV / IR-protection	always active, DIN 16
Filter quality classification	1/2/1/1
Response time (light to dark)	1/30'000 sec
Opening delay (dark to light)	0.25 – 0.8 sec, adjustable
Sensitivity of the optoelectronic sensors	infinitely variable
Operation mode switch	Autodarkening function can be deactivated for grinding
Power supply	solar cell, no changing of batteries necessary
Operating temperature	- 5 °C to 55 °C
Weight	450 g
Warranty	1 year
Technical specifications	according to EN379 and EN175

Ordering information

TBi ArcVisor, (1 helmet with box)	714P101021
TBi ArcVisor, (12 helmets with box)	714P101019

Overview

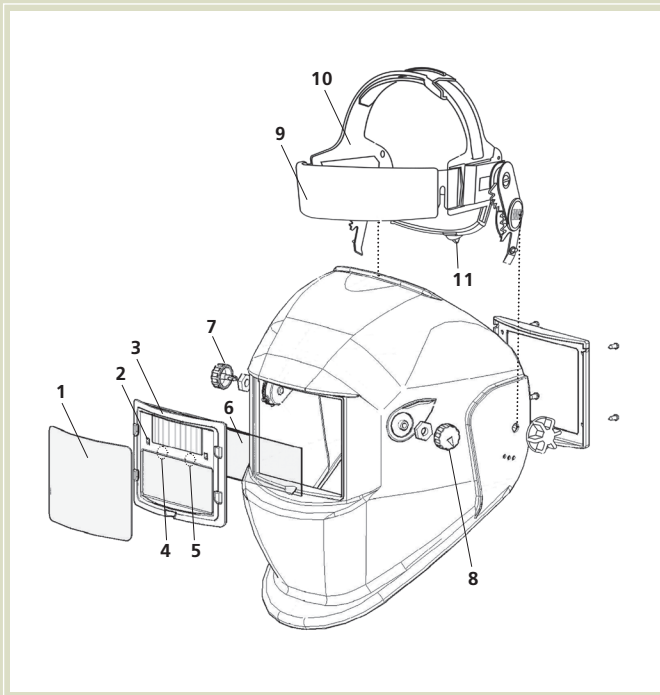

- 1 Outside protective shield
- 2 Sensors
- 3 Autodarkening filter, DIN 9-13
- 4 Slide switch ‚Delay‘ for opening delay time
- 5 Sliding switch for operation mode ‚Mode‘
- 6 Inside protective shield
- 7 Knob ‚Sensitivity‘ for sensor sensitivity
- 8 Shade adjustment knob, DIN 9-13
- 9 Pad
- 10 Head gear assembly, cpl. (without pad)
- 11 Knob for adjustment of the head circumference

Pos. Description Part. no.

Spare parts

1	Outside protective shield	714P002072
3	Autodarkening filter TBi Industries, DIN 9–13	714P102091
6	Inside protective shield	714P102072
9	Pad	714P002059
10	Head gear assembly, cpl. (without pad)	714P002058

Controls

Opening delay

The knob ‚Delay time‘ serves to adjust the opening delay. This is the timespan after which the filter automatically opens again when no arc is detected. This feature prevents premature opening of the filter when the arc is difficult to detect, or when the weld is still hot and glowing right after welding.

Operation mode

The mode switch deactivates the auto-darkening function of the filter. In this setting, the helmet can also be used for grinding.

Dark shade setting

During the welding process, the intensity of the darkening can be infinitely adjusted from DIN 9 to DIN 13 by turning the knob at the outside of the mask. The shade has to be chosen according to the welding process and can be easily adapted to the job.

Sensitivity of the sensors

The sensitivity of the light sensors can be infinitely adjusted with the knob ‚Sensitivity‘. The reaction of the filter changes correspondingly and unwanted activation of the dark shade by surrounding light is avoided.

