

TBi RT 20 TIG Robot welding torch



Advantages

- Very small torch head with high performance
- Very good accessibility due to compact design

Technical data

TBi RT 20 TIG Robot welding torch

Rating / Duty cycle 100%
(10 min. cycle)

- AC	240 A
- DC	340 A
Electrode diameter	0.5 - 3.2 mm
Cooling method	water cooled
Technical specification	according to IEC 60974-7

Ordering information

Part numbers will be provided on request, based on your specific configuration.

Accessories

Cold wire guide:

The torch can easily be equipped with an adjustable cold wire guide, therefore allowing full adaptation to the welding task at hand.

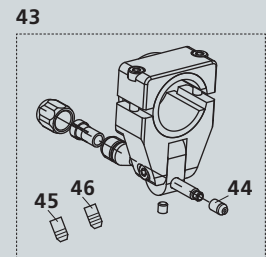
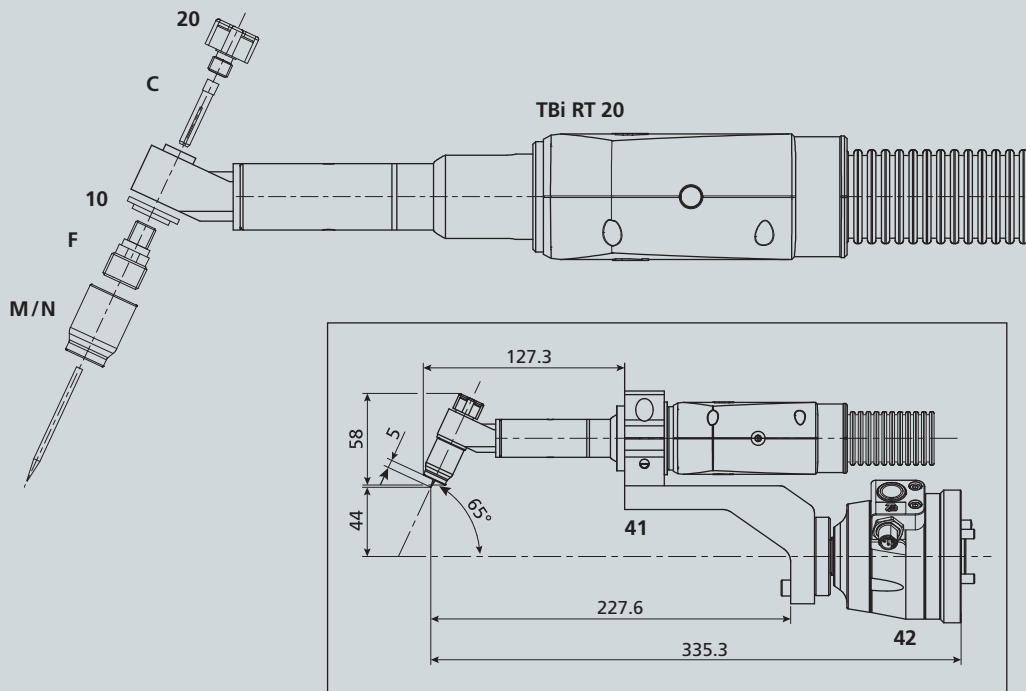

Pos. Description

Part no.

Pos. Description

Part no.

Spare parts

10	Insulator	472P102003
20	Back cap, std.	401P200100

Accessories

41	Torch mount Z-shape	536P101906
42	TBi KS-2-TIG Safety-off mechanism	536P001011
43	Cold wire guide, cpl., 0.8 - 1.2 mm	481P101026
44	Guide nozzle, 0.8 mm (1 groove)	481P102067
45	Guide nozzle, 1.0 mm (2 grooves)	481P102018
46	Guide nozzle, 1.2 mm (3 grooves)	481P102068
47	Guide nozzle, 1.4-1.6 mm (4 grooves)	481P102019

Ø 0.5 mm Ø 1.0 mm Ø 1.6 mm Ø 2.0 mm Ø 2.4 mm Ø 3.2 mm
 Ø 0.020" Ø 0.040" Ø 1/16" Ø 3/32"

Collets

	C Standard, L=25.4 mm	13N20	13N21	13N22	-	13N23	
		401P200599	401P200600	401P200601	401P200604	401P200602	401P200603

Gas lenses

	F Standard, L=21.5 mm	-	45V42	45V43	-	45V44	-
		-	401P201300	401P201301	-	401P201302	401P201303

No. 4 No. 5 No. 6 No. 7 No. 8 No. 10
 Ø 6.5 mm Ø 8.0 mm Ø 9.5 mm Ø 11 mm Ø 12.5 mm Ø 16 mm
 Ø 1/4" Ø 5/16" Ø 3/8" Ø 7/16" Ø 1/2" Ø 5/8"

Ceramic nozzles

	M Gas lens, L=25.5 mm	53N58 401P201400	53N59 401P201401	53N60 401P201402	53N61 401P201403	53N61S 401P201404	- 401P201409
	N Gas lens, L=35.0 mm	-	53N59L 401P201405	53N60L 401P201406	53N61L 401P201407	-	- 401P201410